

# Typical Not for Construction

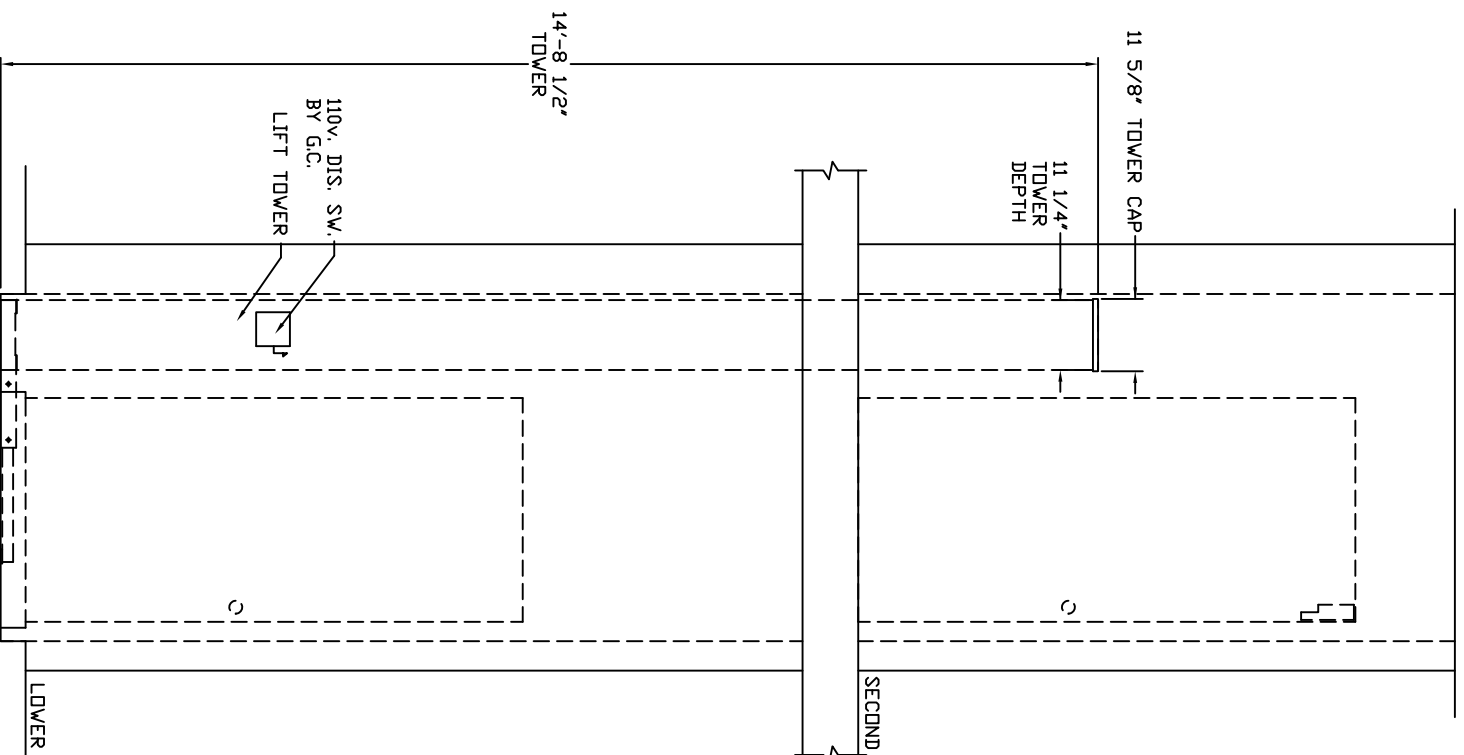

SECTION A-A

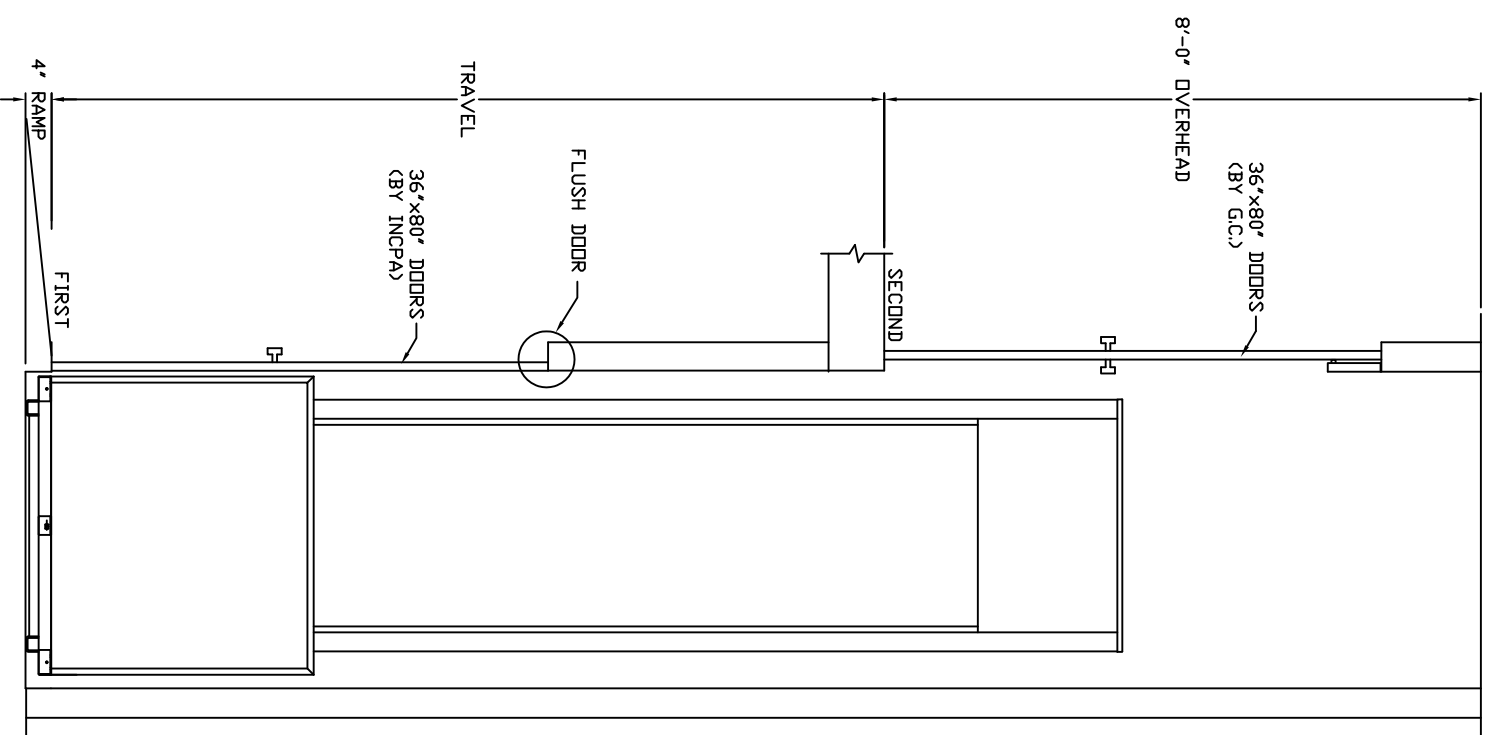

SECTION B-B

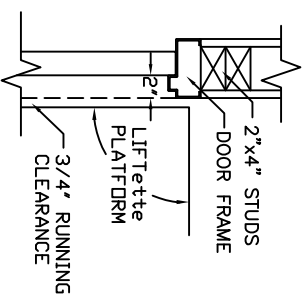

DOOR FRAME DETAIL

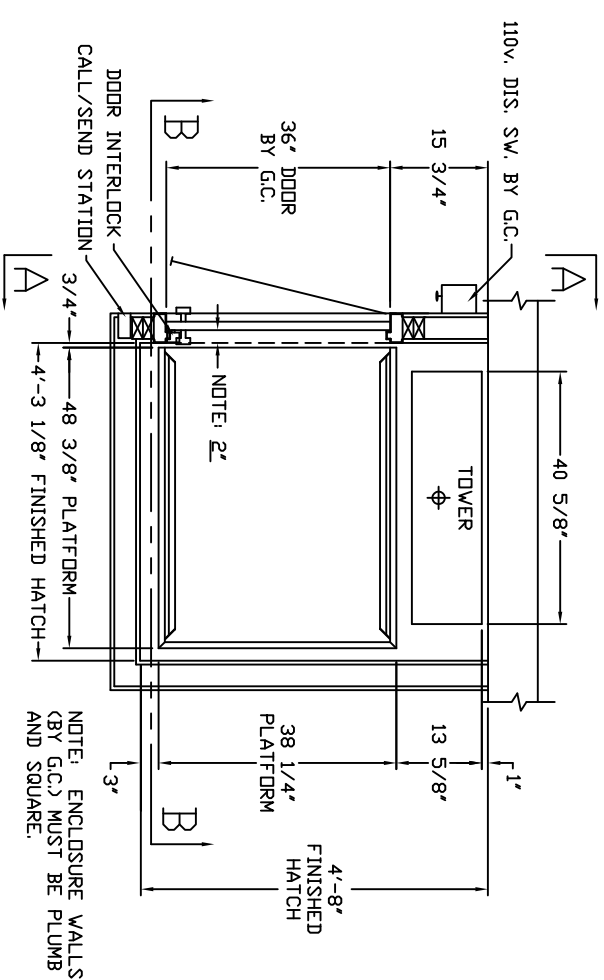
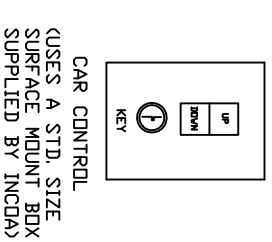
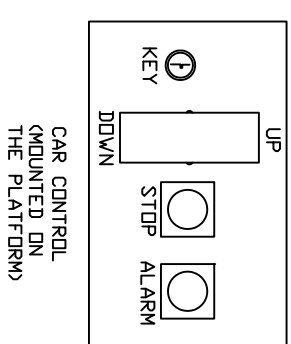

NOTE: ENCLOSURE WALLS (BY G.C.) MUST BE PLUMB AND SQUARE.

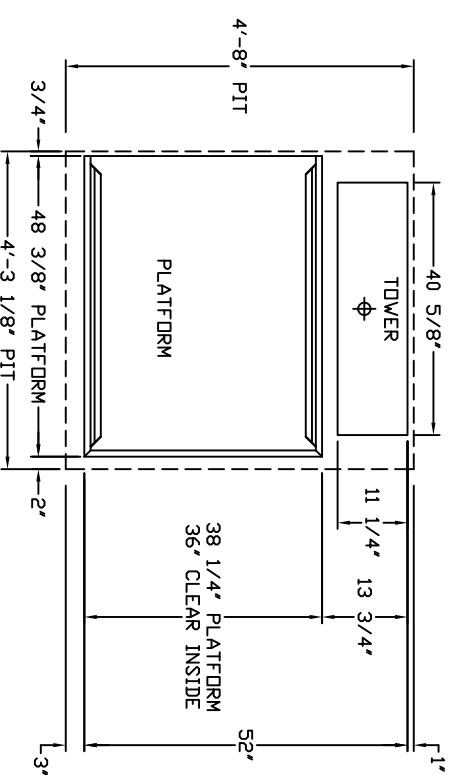

PLATFORM AND TOWER FOOTPRINT



SHOP DRAWING NAME

ARCHITECT

GENERAL CONTRACTOR

EQUIPMENT INSTALLED BY:  
ELEVATOR READY INC.  
5060 RITTER ROAD  
MECHANICSBURG, PA. 17055  
PHONE 717-697-3780  
888-849-4377

SPECIFICATIONS

L-144  
2 LANDING  
VERTICAL LIFT

CAR 36\"/>

- ALL DDORS MUST BE INTERLOCKED
- KEYSWITCH OPERATION
- 12 VOLT DC POWER
- AUTO FOLD RAMP
- STATIONARY RAMP
- LANDING GATE w/ INTERLOCK
- PLATFORM GATE WITH INTERLOCK
- EMERGENCY ALARM
- EMERGENCY STOP
- MANUAL LOWERING
- PLATFORM SAFETY MECHANISM
- INSTANT REVERSE
- LIMIT SWITCHES
- ENCLOSURE DDORS BY INCDA
- ENCLOSURE BY INCDA

NOTICE TO ELECTRICAL CONTRACTOR:  
INSTALL 110V, SINGLE PHASE  
DISCONNECT SWITCH  
1 HP, MOTOR 120V, SINGLE PHASE  
60 CYCLE  
20 AMP MAIN LINE FUSE

INCDA JOB # 99-1245-VL  
DEALER P.D. # LE3621  
DRAWING BY: T. WOODWARD  
DATE: 12/6/99

DRAWING IDENTIFICATION NUMBER

L0185